

Heatpump Controller Manual

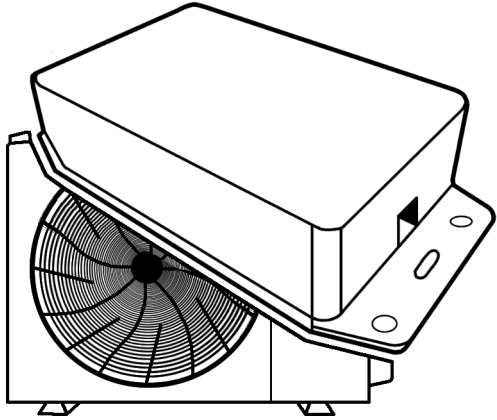

1. Introduction

Thank you for your purchase of the ESPHome-based Midea heat pump controller. This controller is designed for Midea heat pumps with the mod-bus interface, and it's also compatible with Midea clones such as Airwell, Artel, Ferroli, Inventor, Kaisai, and Kaysun. This compatibility ensures you can have complete control over your heat pump system, no matter the brand. With ESPHome at its core, you can easily integrate your heat pump into Home Assistant, an open-source home automation platform.

2. Disclaimer

The seller of this heat pump controller wants to clarify that they are not liable for any damage, malfunctions, or adverse consequences that may arise during the installation or use of this device. It is crucial to engage qualified professionals for installation and operation, adhering strictly to safety guidelines, manufacturer instructions, and local regulations.

Improper installation, maintenance, or misuse of the controller can lead to equipment damage, property issues, or personal injuries. Users must take full responsibility for correctly installing and using the controller, including any associated risks.

Upon purchasing and using this controller, users are acknowledging and accepting these terms, releasing the seller from liability for any problems stemming from its installation or usage.

To ensure safe and proper operation, we strongly recommend consulting with a qualified technician or professional for the installation and maintenance of this heat pump controller.

3. Contents

- 1x Modbus controller
- 1x 1.5m cable
- 1x RJ12
- 5x Ring terminal
- 1x Instruction manual

Optional (if enclosure is selected during order):
 1x Enclosure
 2x Velcro tape

4. Specifications

Board:
 Input voltage : 7 - 28Vac

Enclosure:
 Dimensions : 57 x 85 x 27 mm
 Material : ABS black

5. Installation

Feed the included cable into the heatpump's remote control unit.

Connect the ring terminals as follows:

- A: Blue (AC)
- B: Red (AC)
- E: Black (GND)
- H1: Yellow (A-)
- H2: Green (B+)

WARNING!
 Follow the colors of the ring terminal connectors and not the wire itself. Wiring the cable incorrectly will damage the heatpump controller.

Always double-check the connections before connecting the heatpump controller.

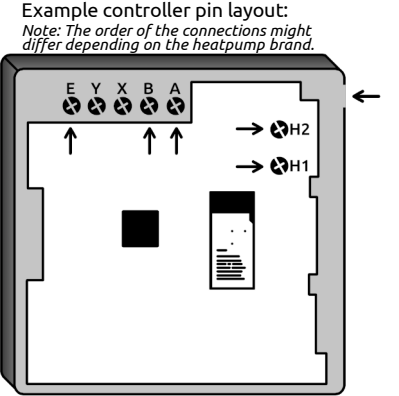

6. Network connection

The modbus controller will power up after installation and, when unconfigured, will create a WiFi-network called "heatpump-setup".

The password of this AP network is **heatpump**
 To configure a network for the controller to connect to, in a web browser visit <http://192.168.4.1/>
 From there the correct WiFi network can be set-up.

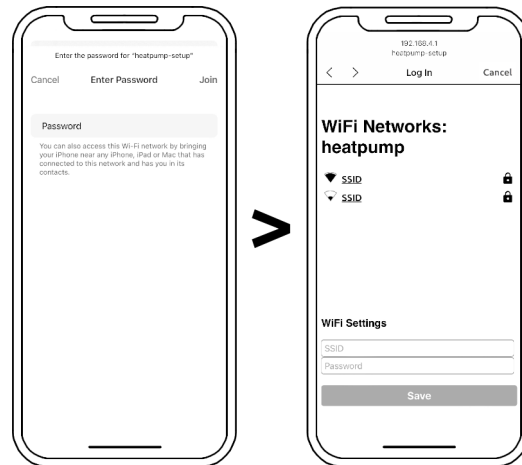

7. Home Assistant

After a successful WiFi connection, Home Assistant will show a notification about a newly discovered device. All entities will become available after clicking *configure*.

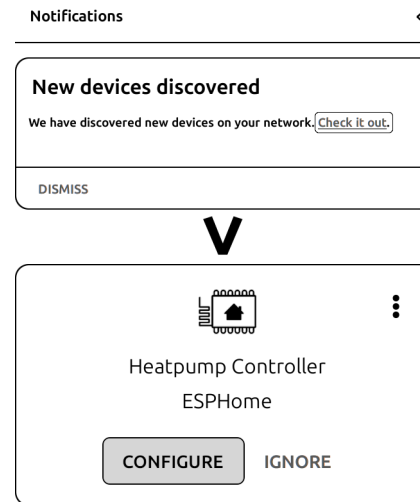

8. Flashing

In addition to the regular OTA upgrade method, the heat pump controller also supports firmware flashing through the onboard pins using a USB to serial adapter, this can be used as an alternative update option without a WiFi-connection.

- Connections:
 3v3 : 3v3
 GND : GND
 RST : RTS
 RX : TX
 TX : RX
 FLASH : DTR

